

BODY DIMENSIONS

SEDAN MODEL

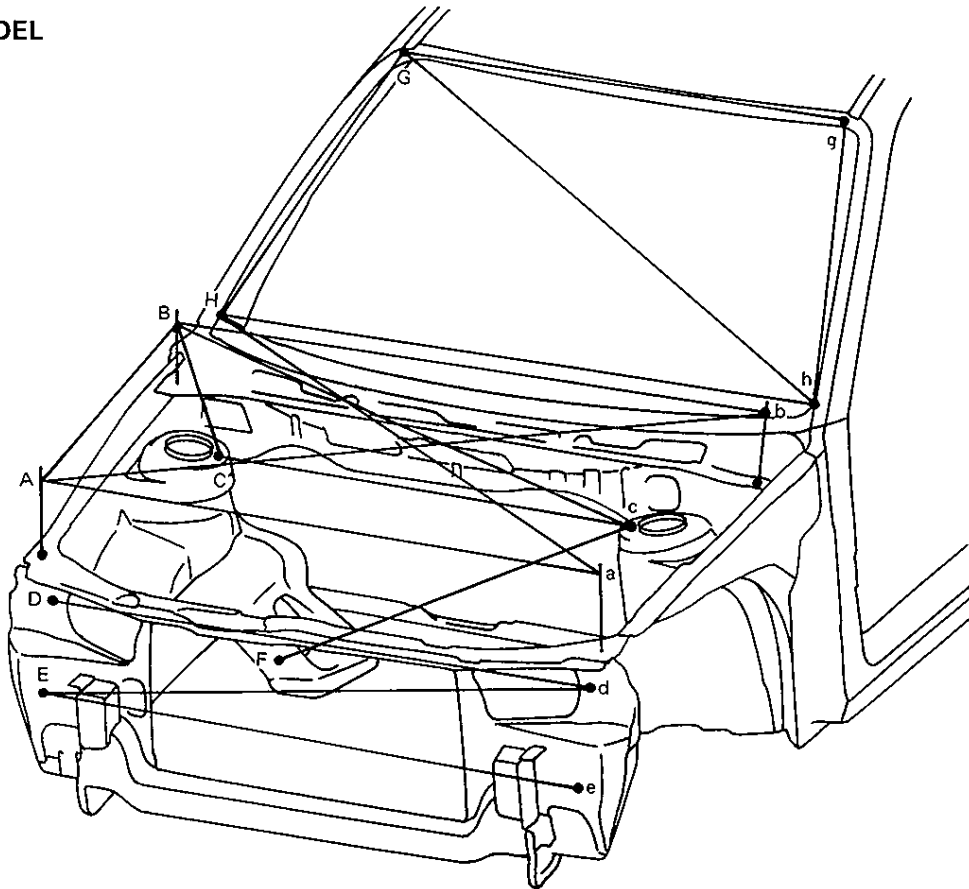

A: 6 mm
NUT

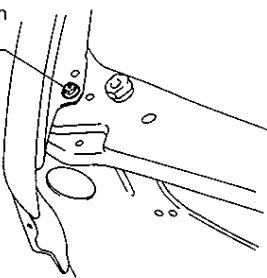

A

B: Ø8, HOLE

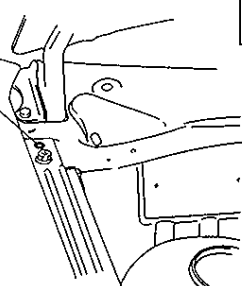

B

d: Ø8, HOLE

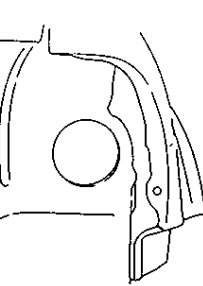

D

E: Ø7,
HOLE

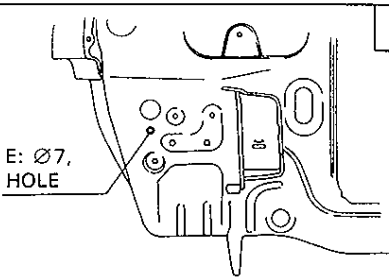

E

G

G

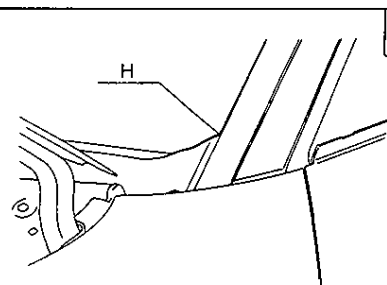

H

MEASUREMENT POSITION	LENGTH mm (in.)	MEASUREMENT POSITION	LENGTH mm (in.)
A-a	1237 (48.70)	D-d	1174 (46.22)
A-b	1476 (58.11)	E-d	1243 (48.94)
A-B	676 (26.61)	E-e	1270 (50.00)
B-b	1352 (53.23)	F-c	983 (38.70)
B-C	279 (10.98)	G-g	972 (38.27)
B-c	1167 (45.94)	G-h	1255 (49.41)
C-c	950 (37.40)	H-h	1353 (53.27)

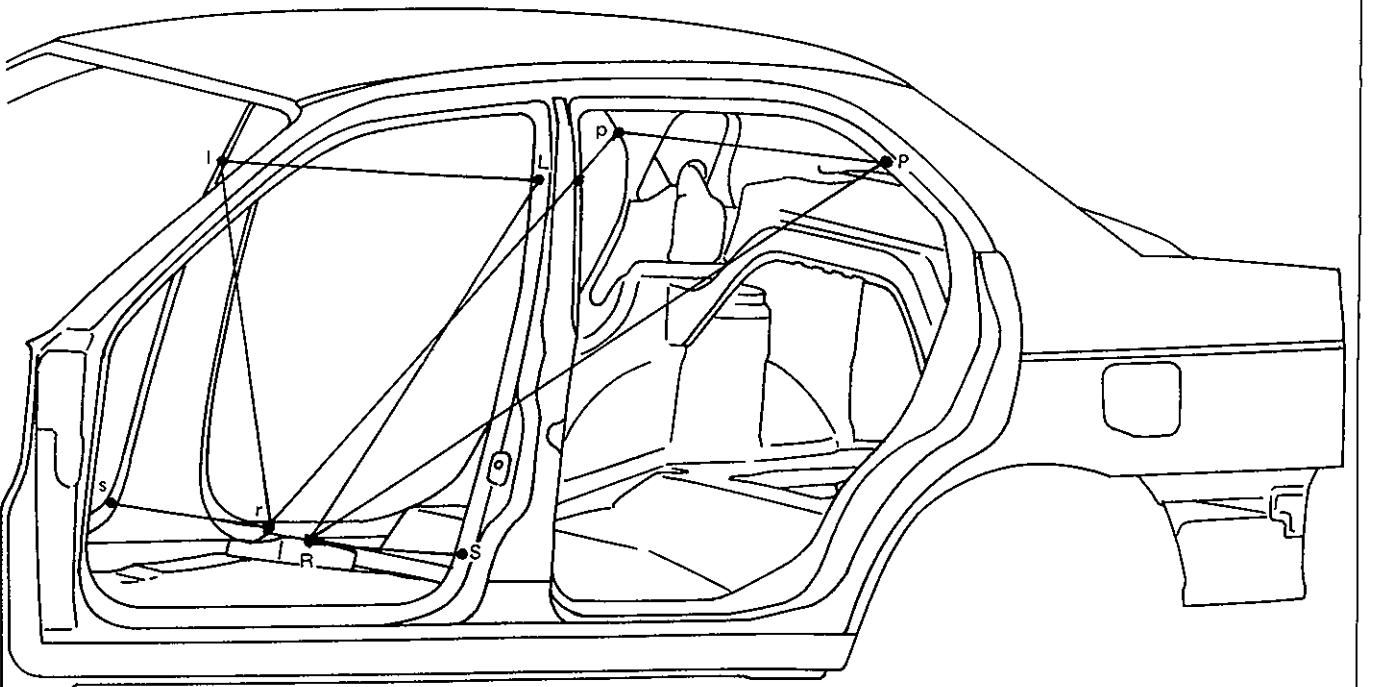
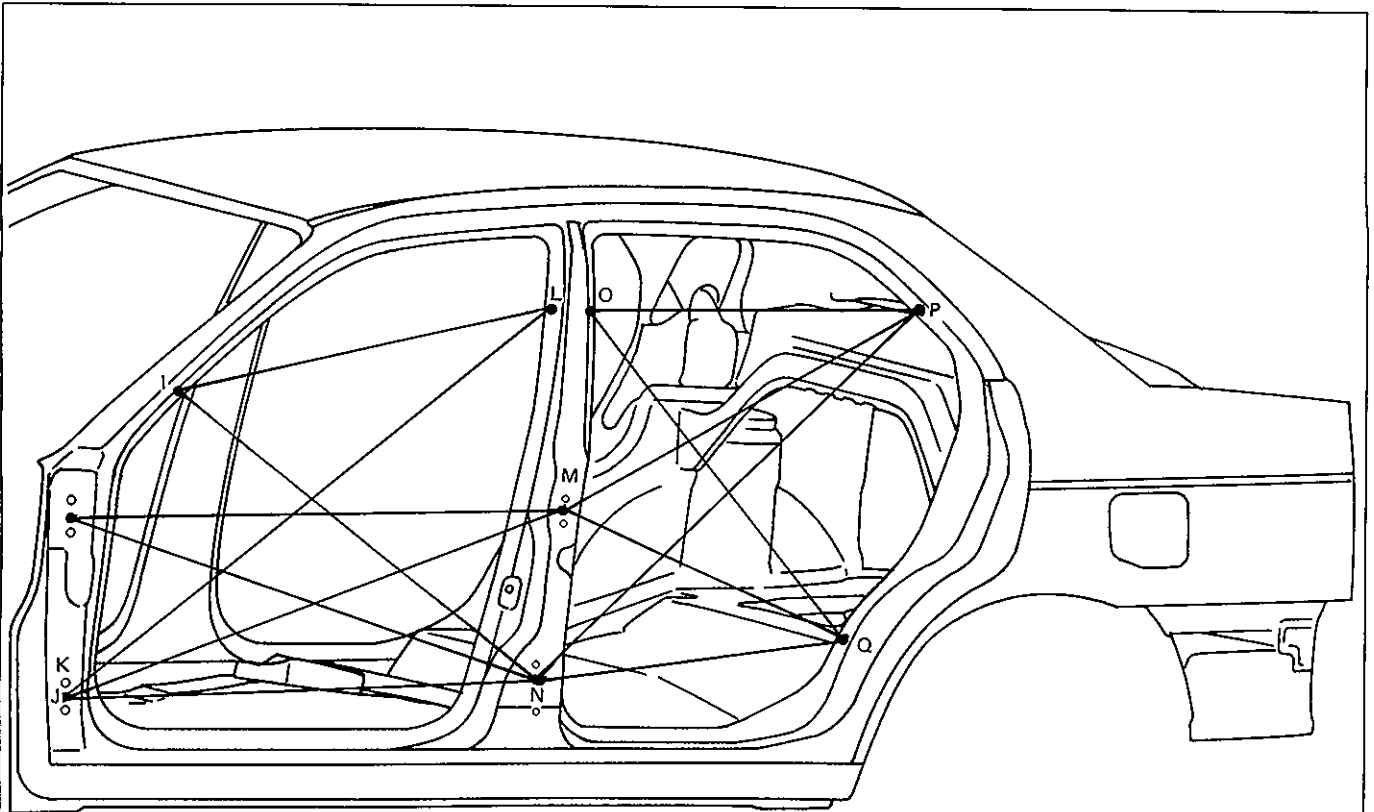

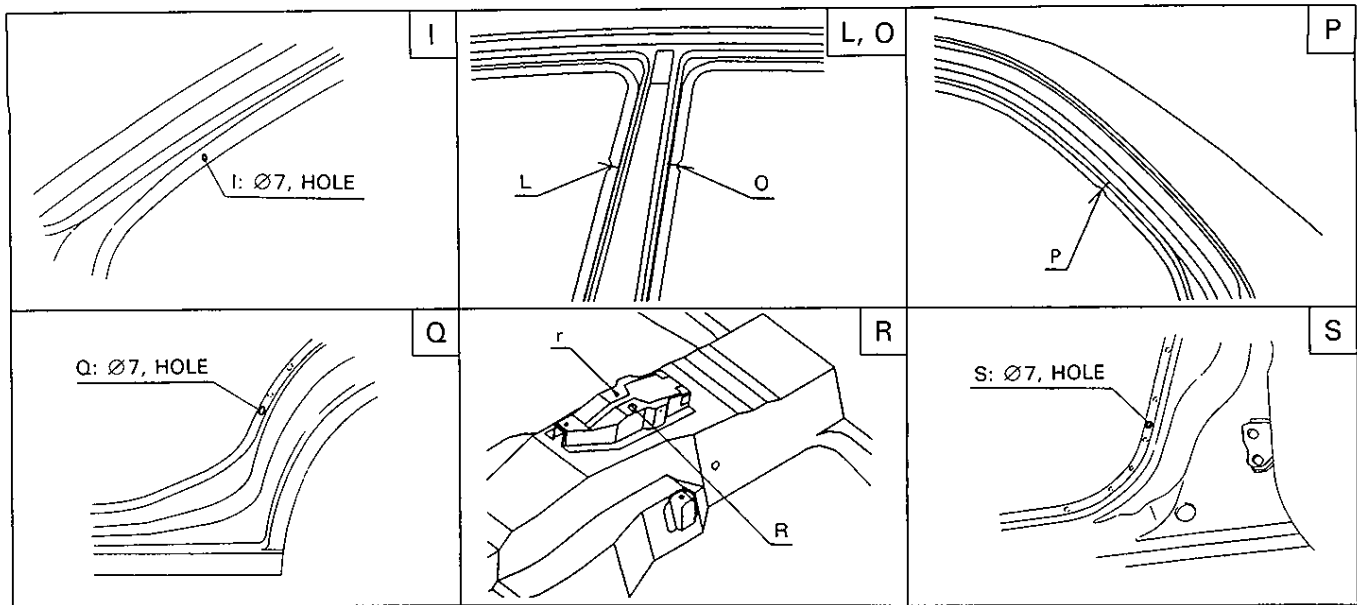

MEASUREMENT POSITION	LENGTH mm (in.)	MEASUREMENT POSITION	LENGTH mm (in.)
I-L	833 (32.80)	M-P	923 (36.34)
I-N	941 (37.05)	M-Q	708 (27.87)
J-M	1046 (41.18)	N-P	1104 (43.46)
J-N	1081 (42.56)	N-Q	673 (26.50)
K-L	1316 (51.81)	R-L	966 (38.03)
K-M	1102 (43.39)	R-P	1332 (52.44)
K-N	1037 (40.83)	R-S	691 (27.20)
O-P	685 (26.97)	r-l	948 (37.32)
O-Q	821 (32.32)	r-p	1320 (51.97)
		r-s	661 (26.02)

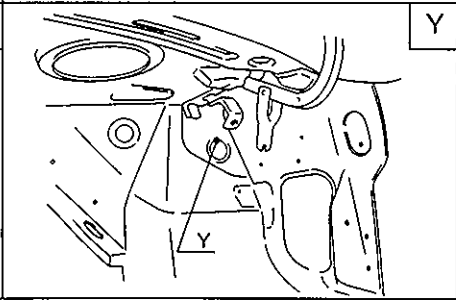
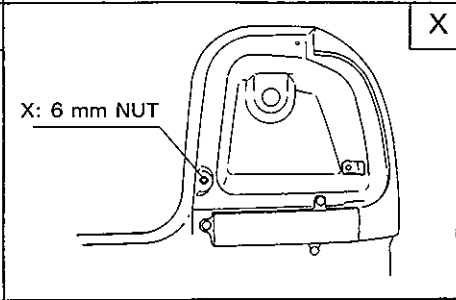
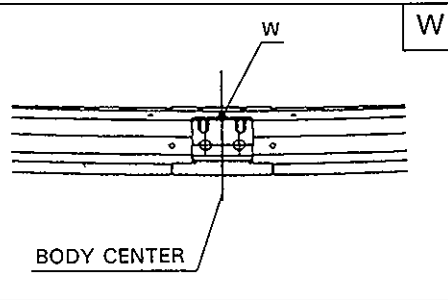
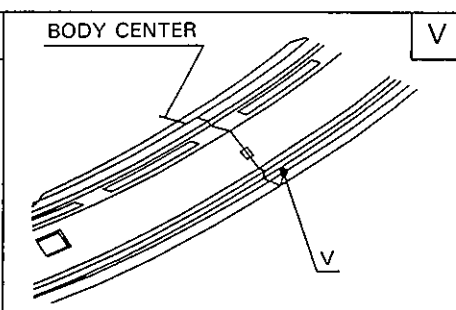
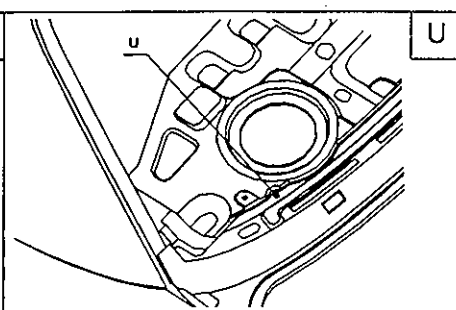
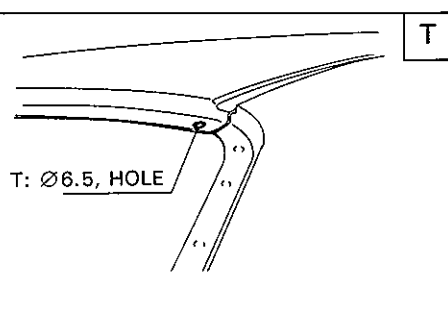
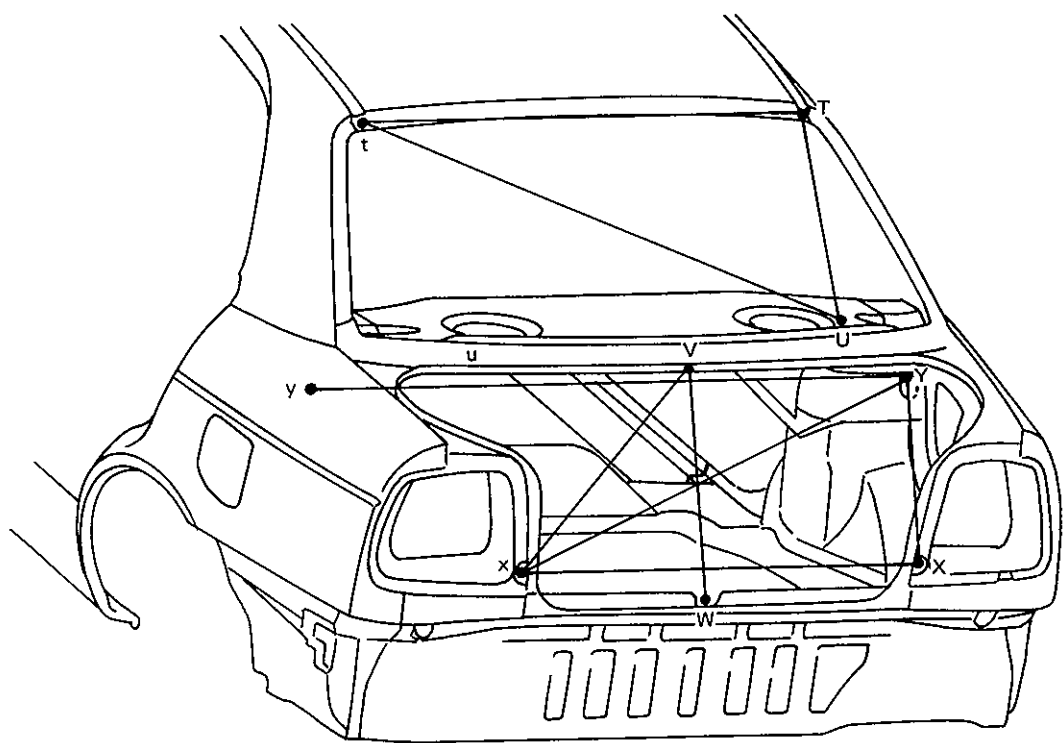

MEASUREMENT POSITION	LENGTH mm (in.)	MEASUREMENT POSITION	LENGTH mm (in.)
T-t	898 (35.35)	X-x	825 (32.48)
T-U	514 (20.24)	Y-X	694 (27.32)
t-U	991 (39.02)	Y-x	1247 (49.09)
V-x	1046 (41.18)	Y-y	1300 (51.18)
V-W	458 (18.03)		

HATCH-BACK MODEL**NOTE:**

For measurement from A-a to H-h, refer to one of sedan model.

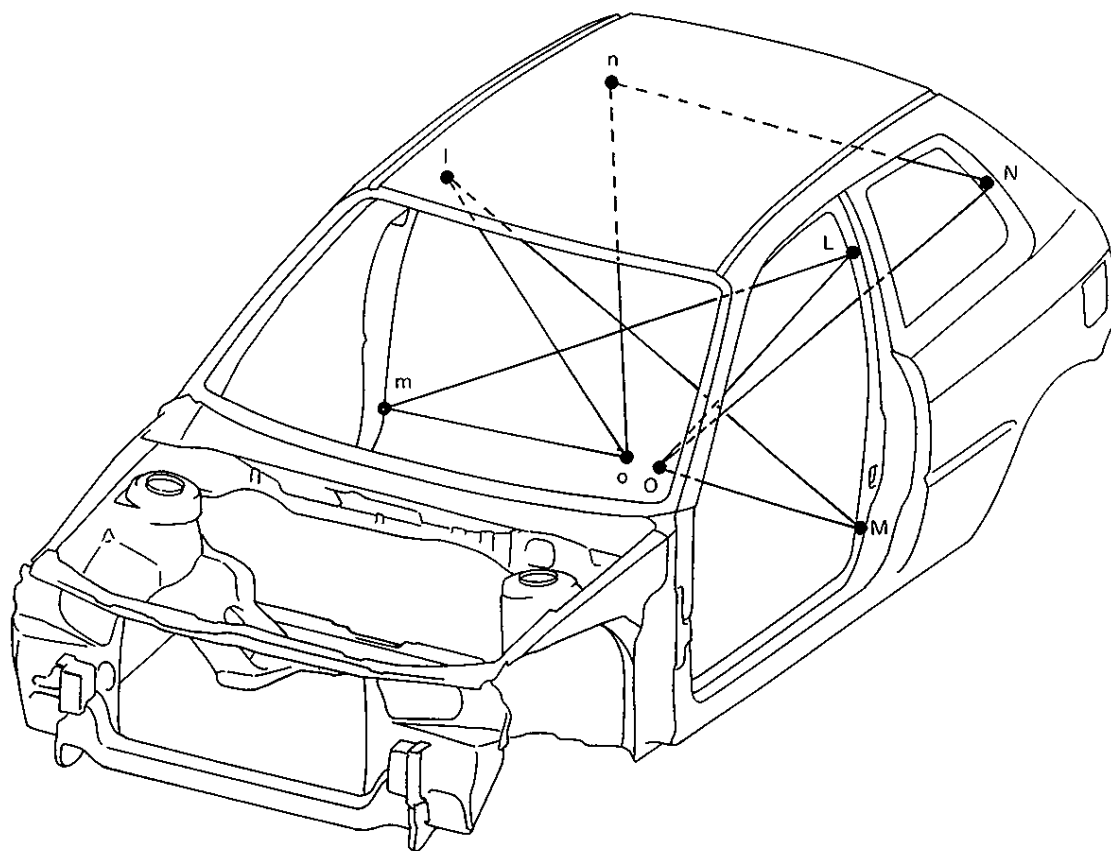
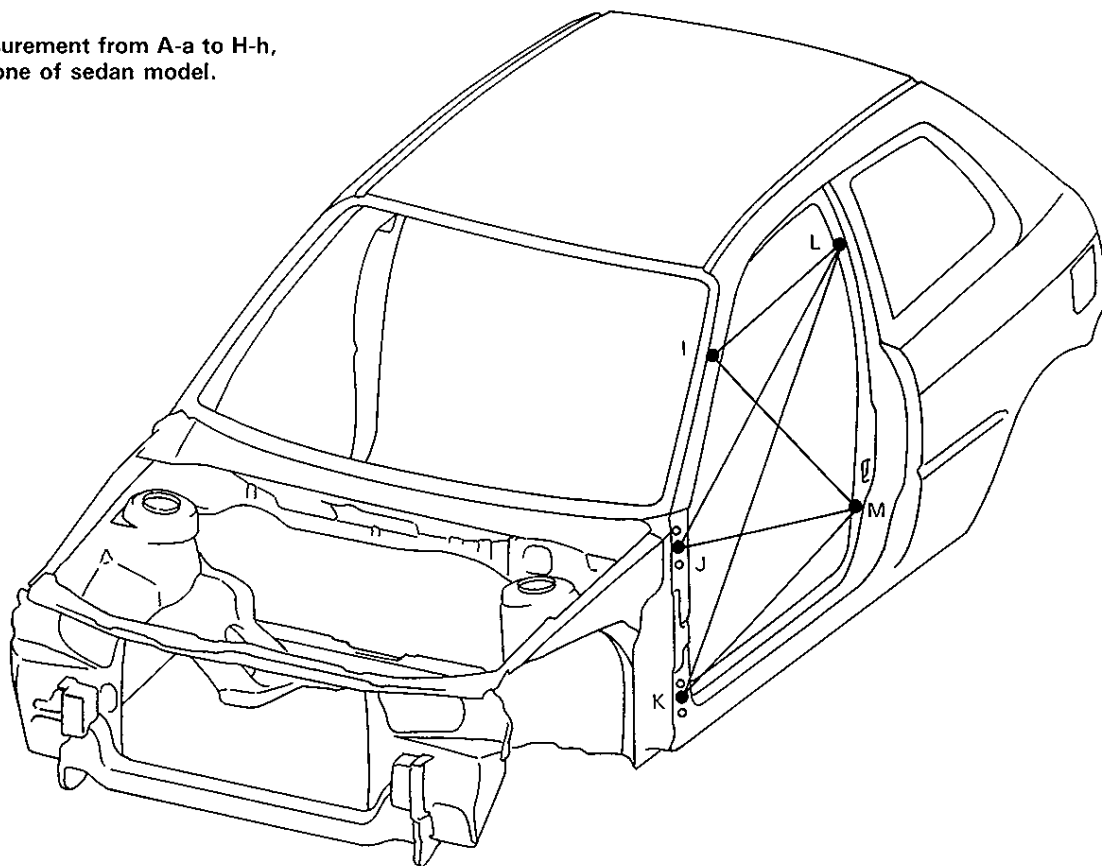

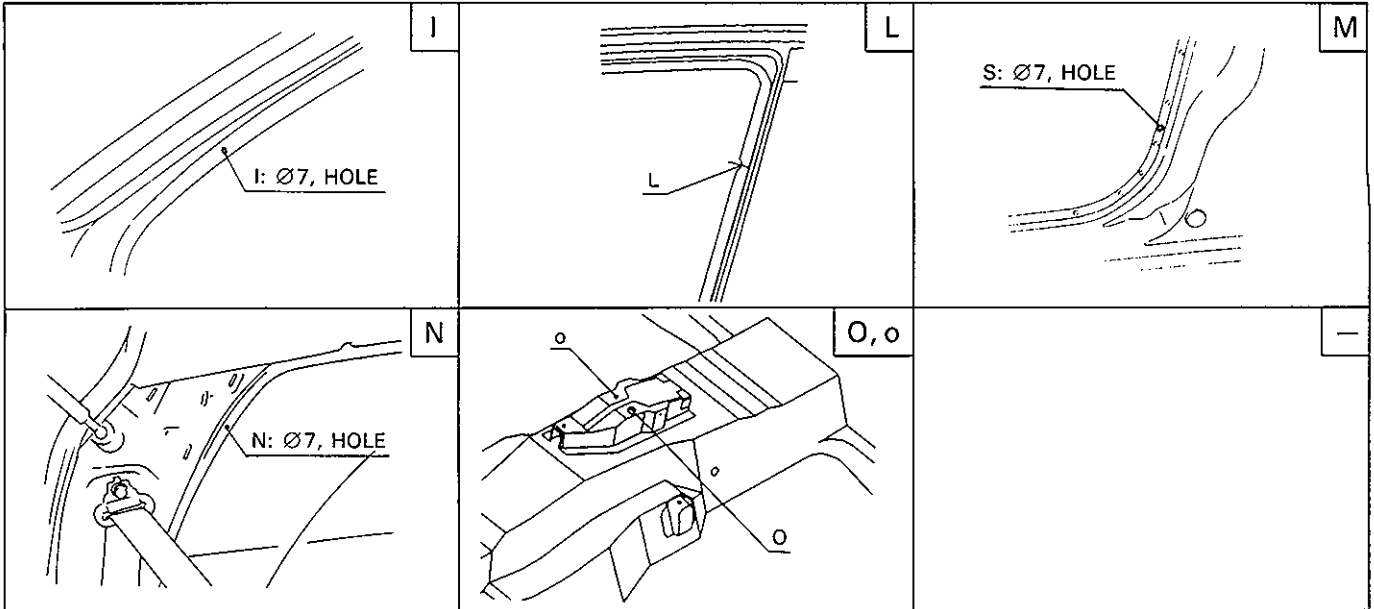

MEASUREMENT POSITION	LENGTH mm (in.)	MEASUREMENT POSITION	LENGTH mm (in.)
I-L	665 (26.18)	L-O	998 (39.29)
I-M	870 (34.25)	I-M	1418 (55.83)
J-L	1268 (49.92)	I-o	980 (38.58)
J-M	1179 (46.42)	m-l	1418 (55.83)
K-L	1411 (55.55)	m-o	722 (28.43)
K-M	1172 (46.14)	N-n	1226 (48.27)
L-m	1418 (55.83)	N-O	1319 (51.93)
		n-o	1306 (51.42)

61G00-9-71-1

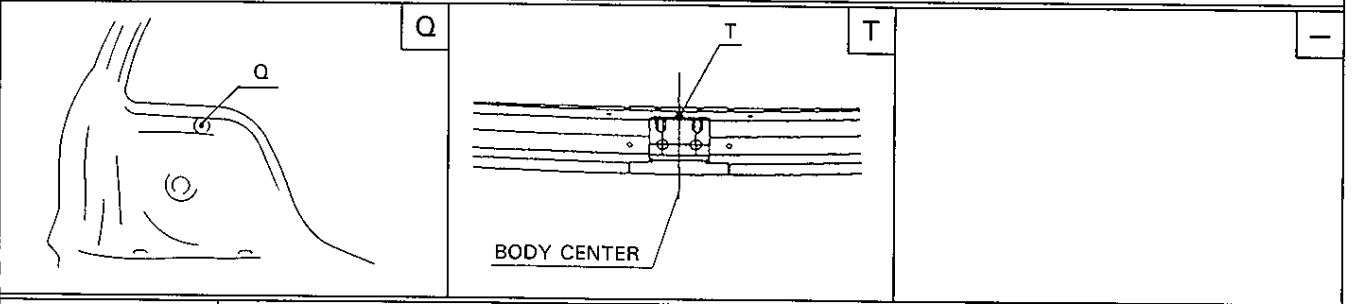
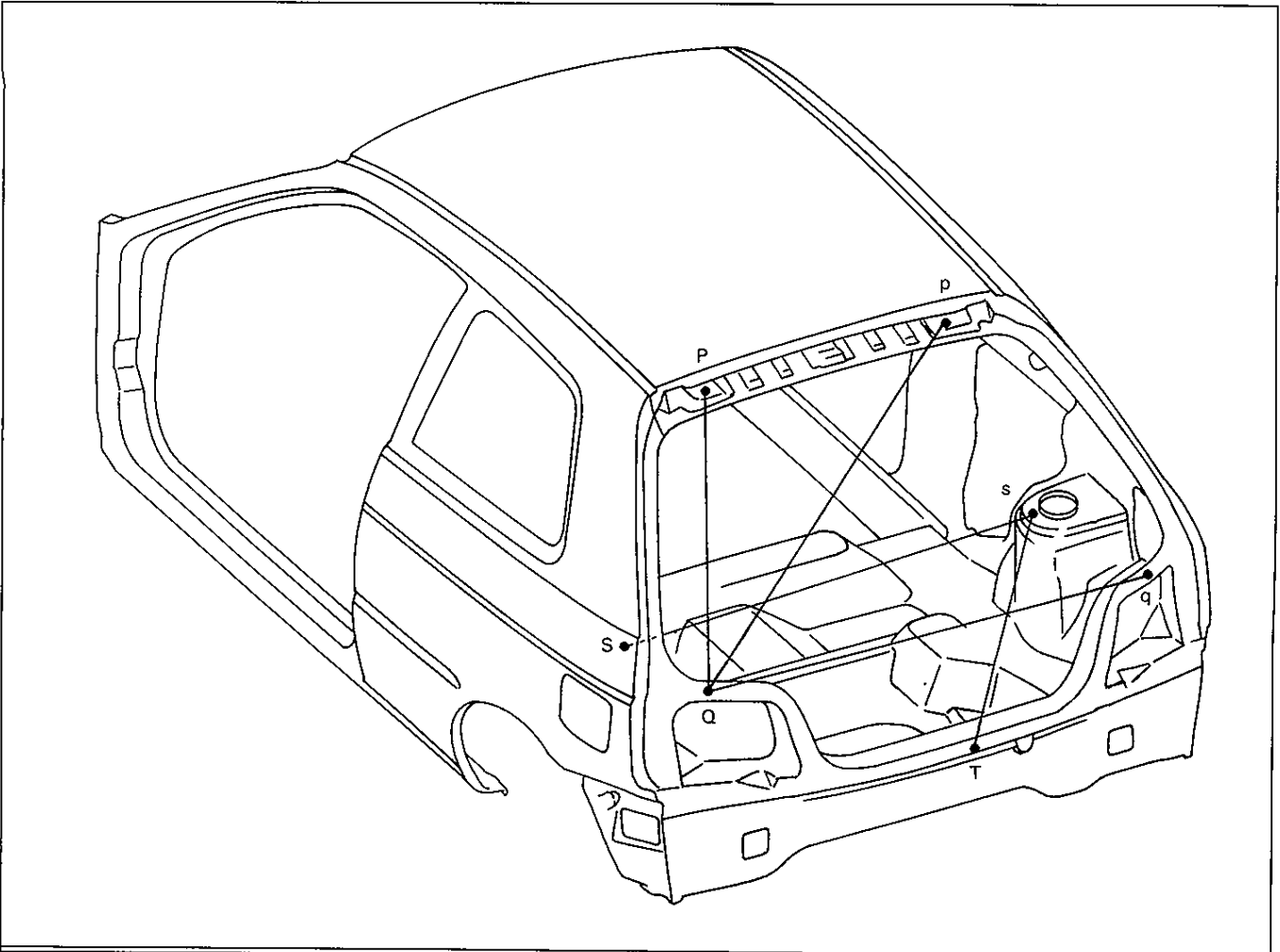

MEASUREMENT POSITION	LENGTH mm (in.)
P-Q	729 (28.70)
p-Q	1096 (43.15)
Q-q	1031 (40.59)
S-s	988 (38.90)
T-s	659 (25.94)

UNDERBODY DIMENSIONS

Each underbody component affects strength of vehicle itself as well as wheel alignment (toe-in, camber, caster).

It is essential, therefore, to check underbody carefully and perform welding properly, if necessary for its correction or replacement. When damage is found in sealing or rust proof treatment, it is mandatory to correct it properly. For sealing and rust proof treatment, refer to "ANTI-CORROSION TREATMENT" section.

50G00-9-59-1

SEDAN MODEL

Unit: mm

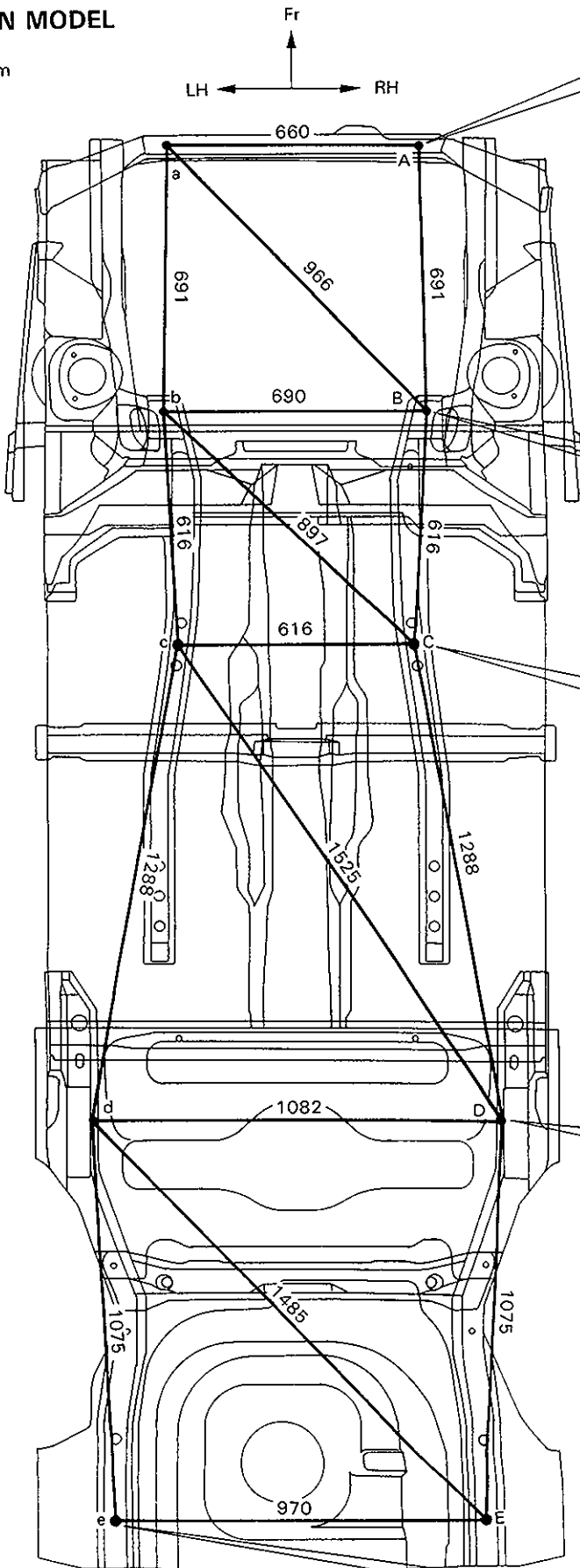

A: Ø20, HOLE

B: Ø14, HOLE

C: Ø20, HOLE

D: Ø12, HOLE

e: Ø25, HOLE

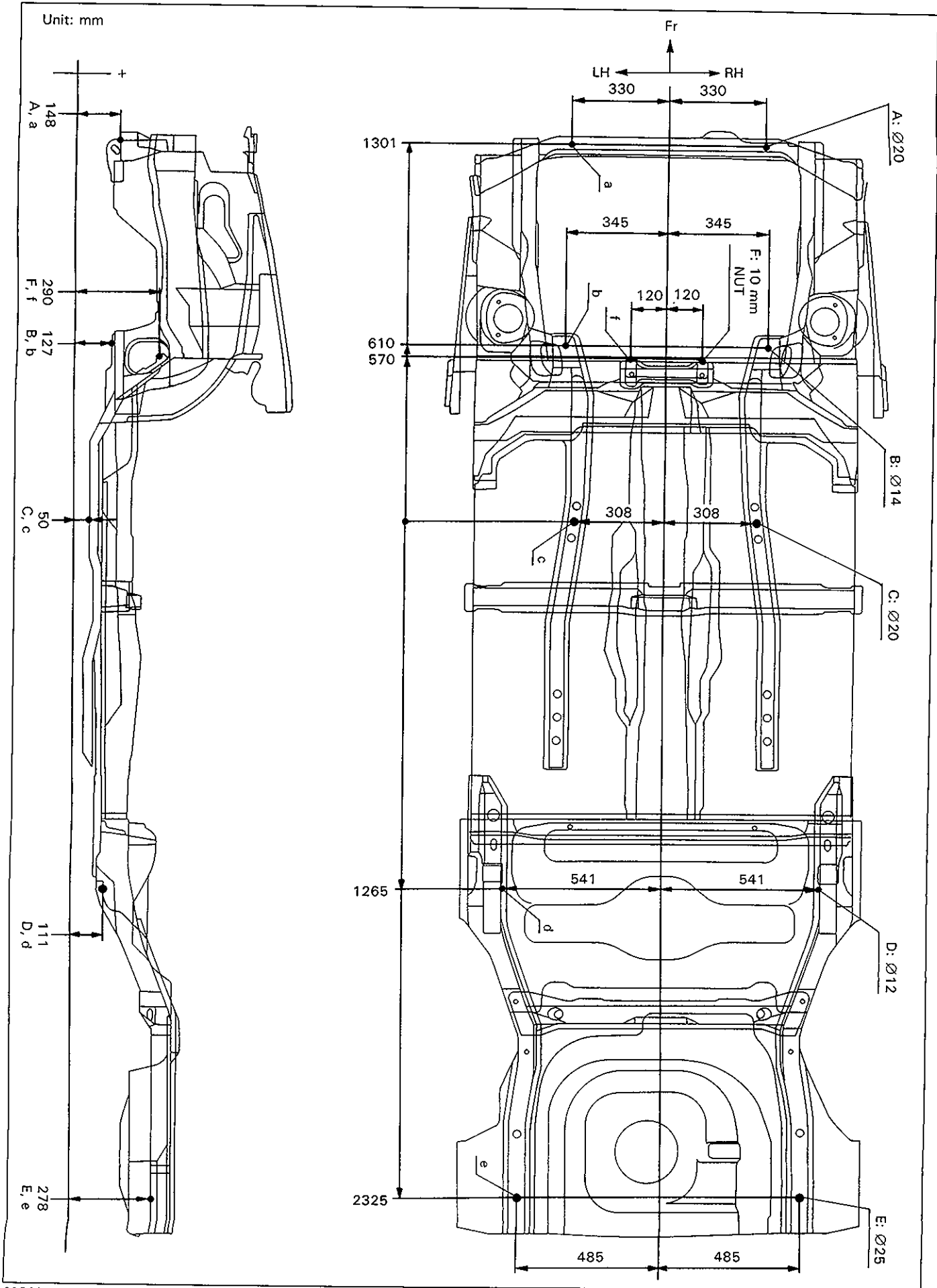

HATCH-BACK MODEL

Unit: mm

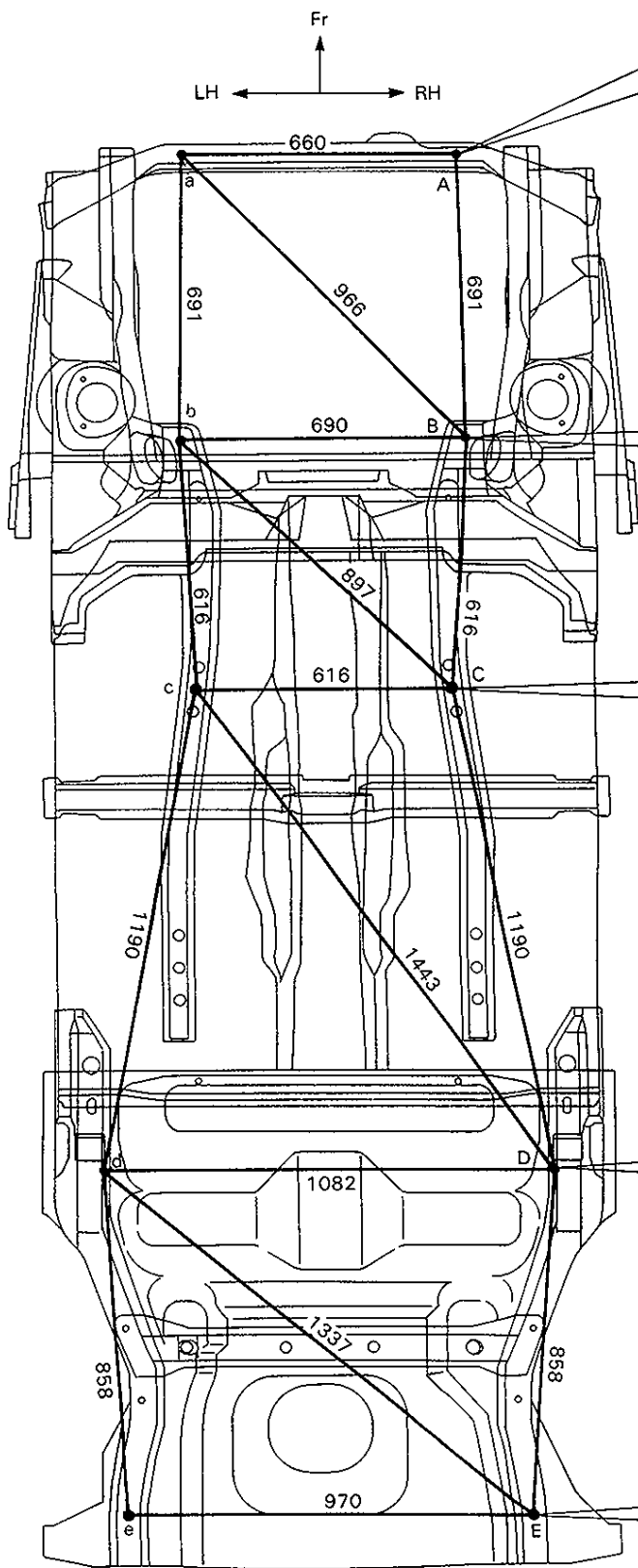

A: Ø20, HOLE

B: Ø14, HOLE

C: Ø20, HOLE

D: Ø12, HOLE

E: Ø25, HOLE

Unit: mm

